

ITEM NO.	PART NUMBER	DESCRIPTION	QTY.
1	AL-16723A-18	2" X 10" NOMINAL BLEACHER PLANK ANODIZED FINISH - 18'-0"	1
2	BL-60	60" SPACER BRACE	3
3	BL-20774	RETAINER CLIP - ALUMINUM	8
4	BL-EC16723	MOLDED END CAP-INSERT-BLACK POLYCARBONATE	2
5	BL-PB-05	PLAYERS BENCH STRINGER	4
6	HW-613A-034WJ	WHITE NEOPRENE RUBBER BUMPER	8
7	HW-B-40000	3/8" x 1-1/4" MG, GR 5, HEX BOLT	4
8	HW-B-50005	5/16" x 1-1/4" HDG, GR 2 CARRIAGE BOLT	16
9	HW-N-10002	5/16" HDG. GR. 2 HEX NUT	16
10	HW-R-10000	ALUMINUM POP RIVET 3/16" x 0.251-0.375	4
11	HW-W-1000-Z	3/8" ZP, WASHER USS	8
12	HW-W-20002	5/16" LOCK WASHER, HDG.	16
13	HW-N-10000	3/8" SERRATED FLANGE NUT MG.	4

REVISIONS			
REV.	DESCRIPTION	DATE	APPROVED

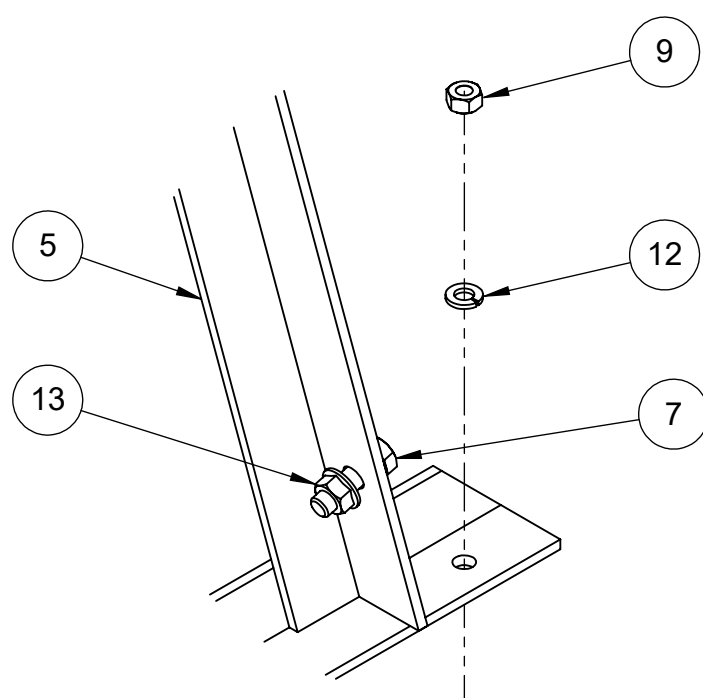

DETAIL A
SCALE 1 : 3
RUBBER BUMPER

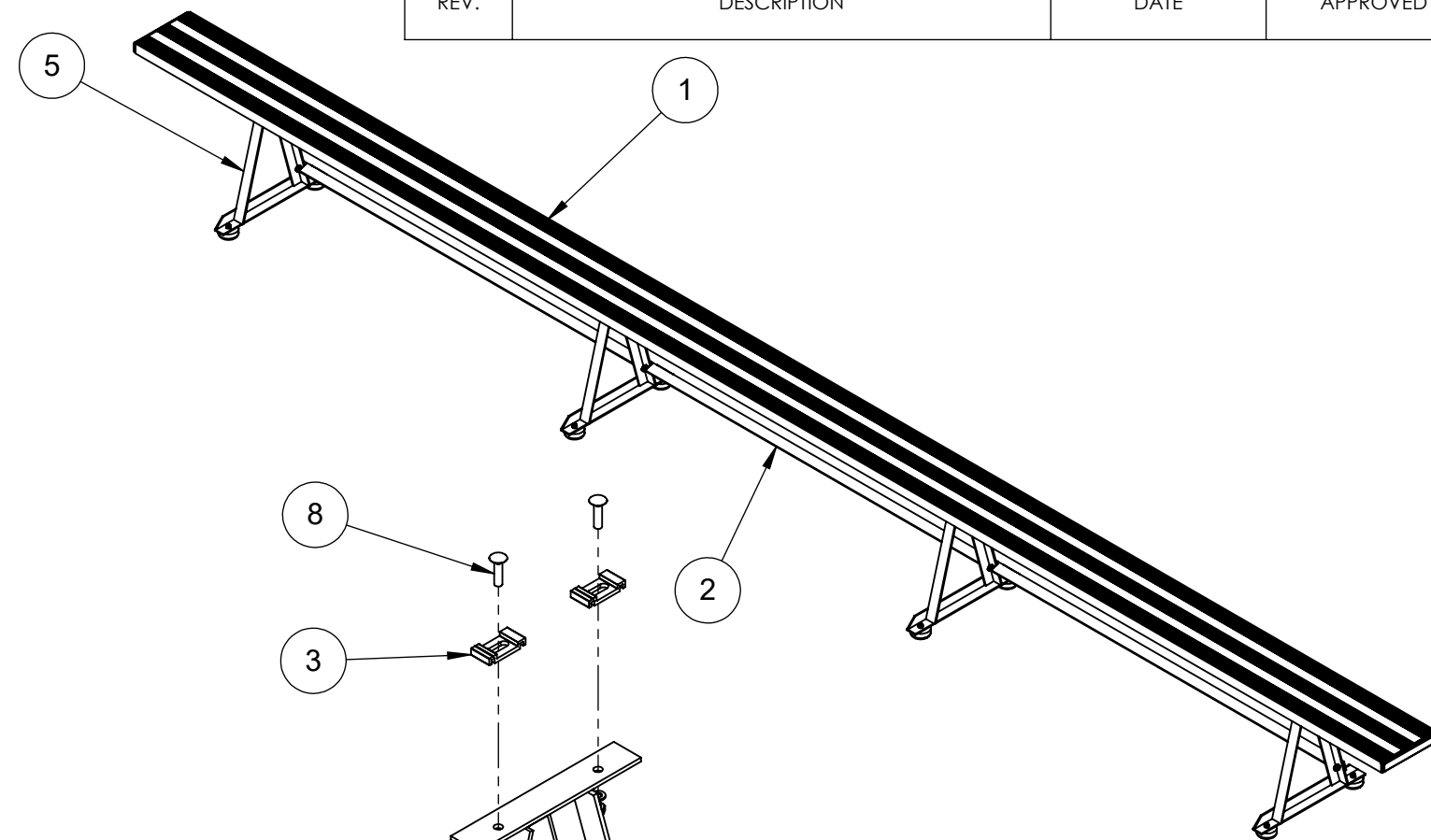
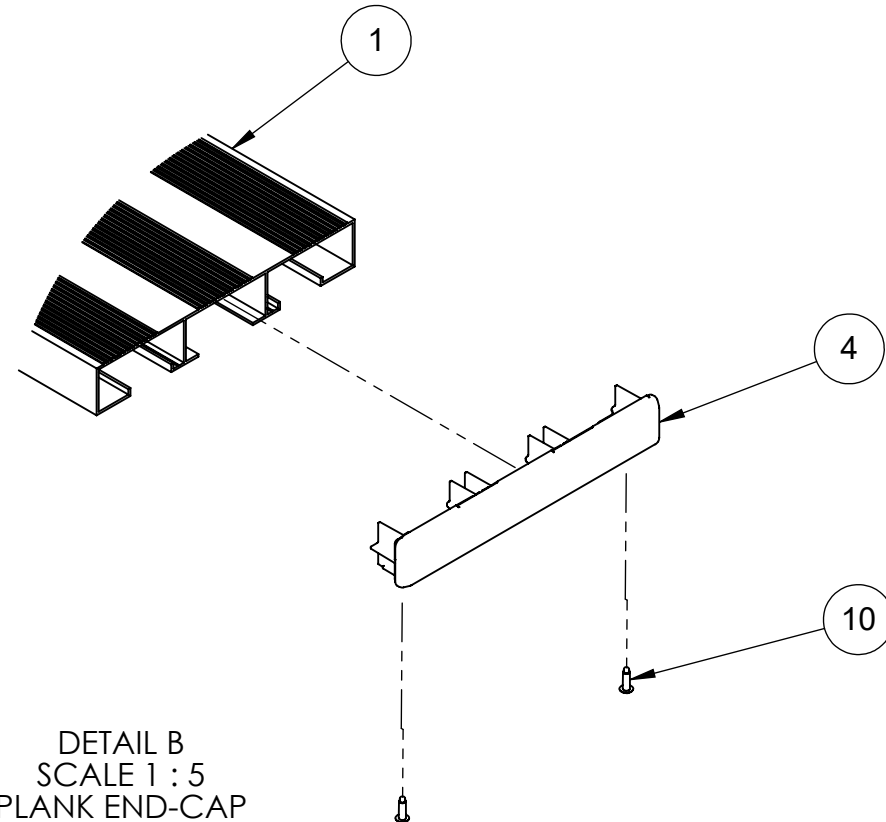

DETAIL B
SCALE 1 : 5
PLANK END-CAP

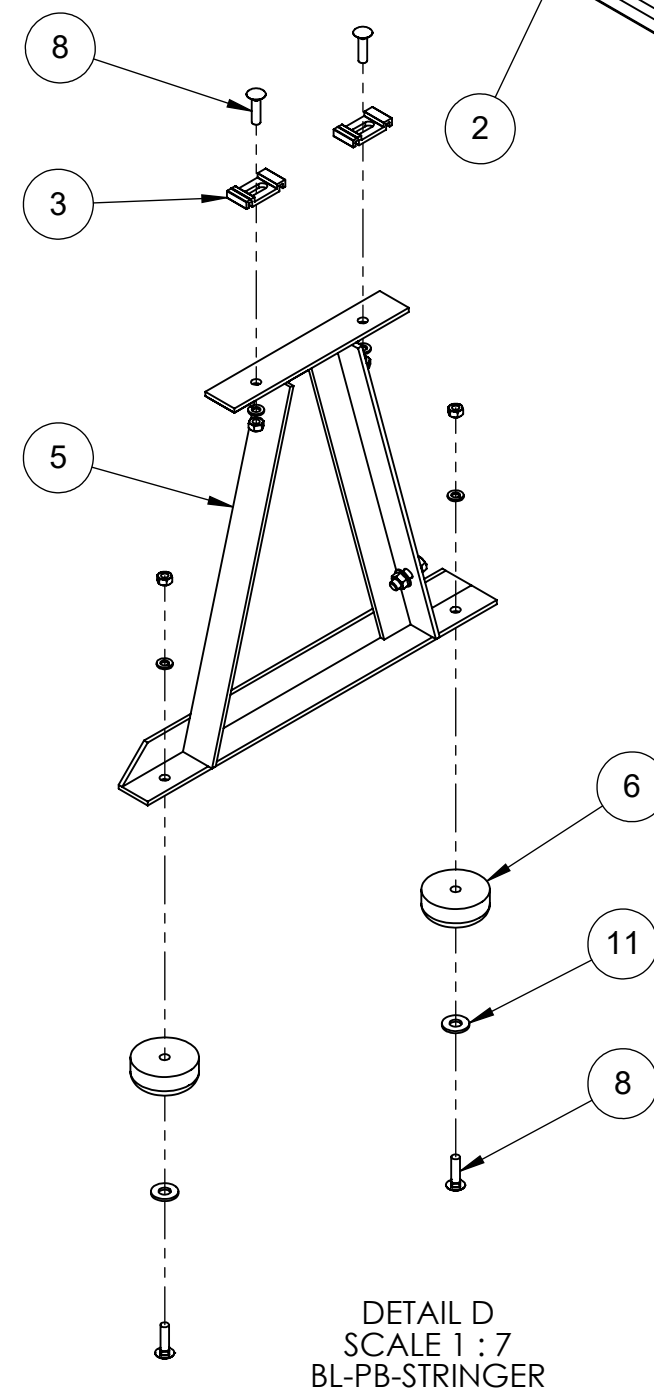

DETAIL D
SCALE 1 : 7
BL-PB-STRINGER

THIS DRAWING AND ALL INFORMATION CONTAINED HEREIN IS THE PROPERTY OF SPORT SYSTEMS CANADA INC. AND IS NOT TO BE REPRODUCED WITHOUT THE WRITTEN PERMISSION OF THIS MANUFACTURER. WE ASSUME NO RESPONSIBILITY FOR UNAUTHORIZED USE OF THIS DRAWING. SPORT SYSTEMS CANADA INC. IS NOT RESPONSIBLE FOR LOCAL PERMITS AND OCCUPANCY REQUIREMENTS.



28 Industrial Drive, Box 940
Almonte, Ontario, Canada
K0A 1A0

www.ssci.ca
1.877.600.4667
T 613.256.1112
F 613.256.5876

CLIENT
SPORT SYSTEMS

TITLE
BL-PLAYER'S BENCH - 18'

REV.	DATE	DWG No.
	2021-11-08	BL-PB-18

SCALE	DES.	PAGE
N.T.S.	BAT	1 OF 2

REVISIONS			
REV.	DESCRIPTION	DATE	APPROVED

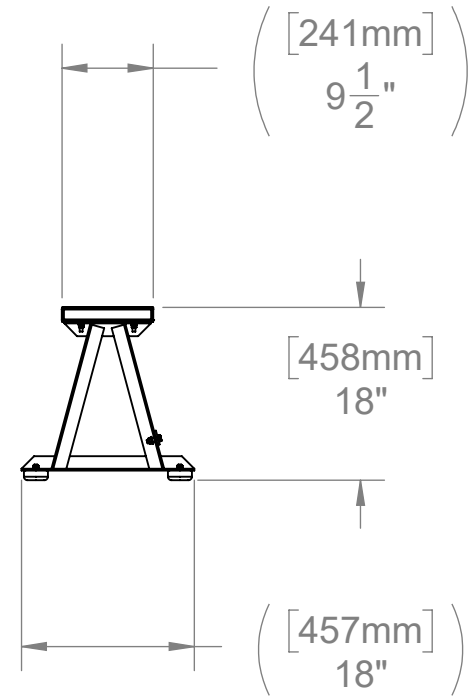
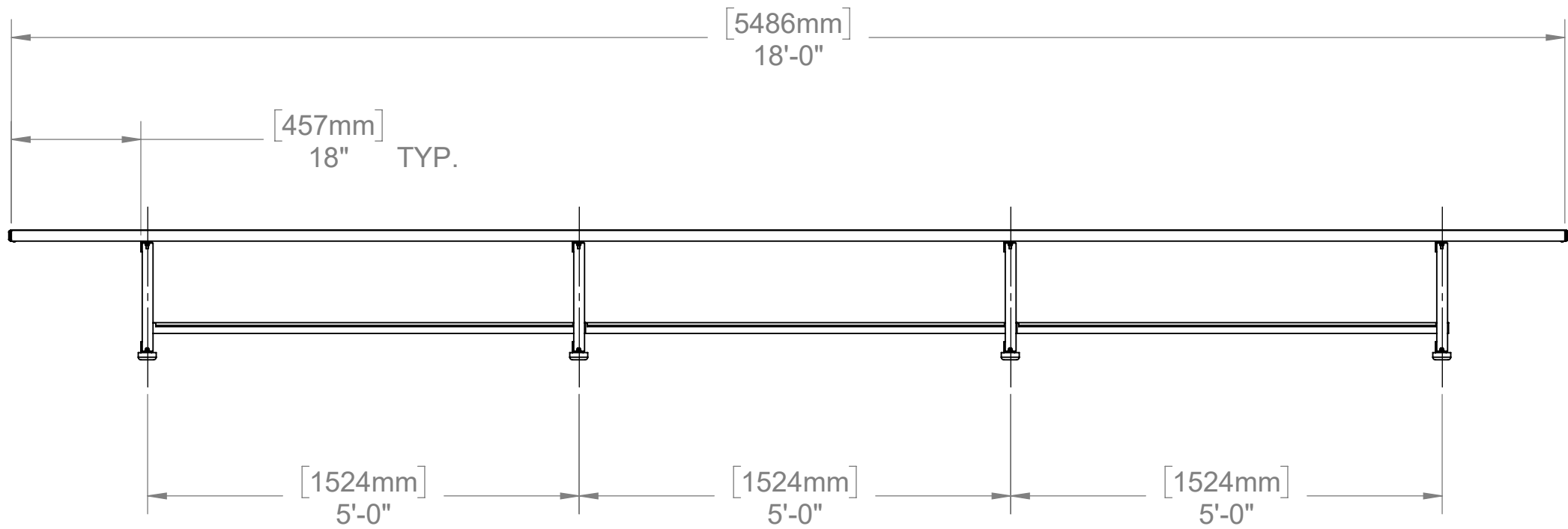
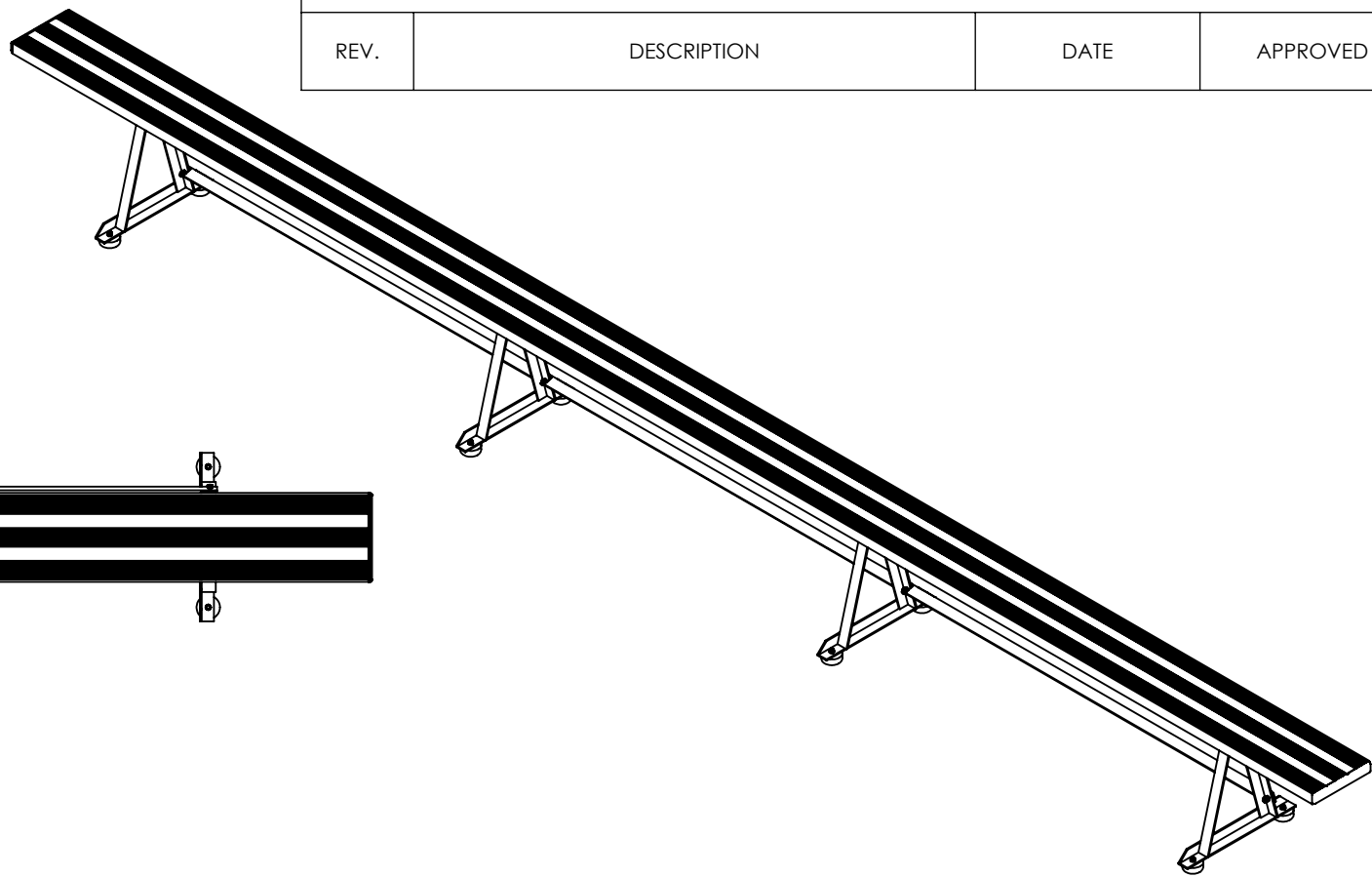
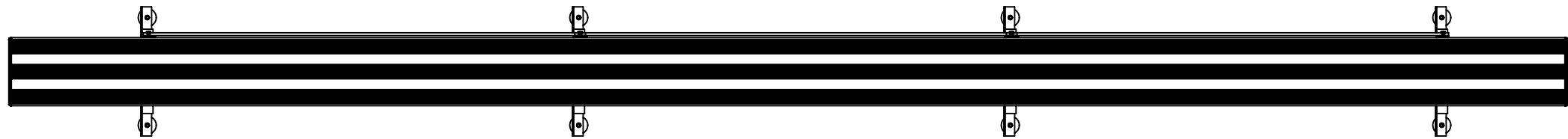

THIS DRAWING AND ALL INFORMATION CONTAINED HEREIN IS THE PROPERTY OF SPORT SYSTEMS CANADA INC. AND IS NOT TO BE REPRODUCED WITHOUT THE WRITTEN PERMISSION OF THIS MANUFACTURER. WE ASSUME NO RESPONSIBILITY FOR UNAUTHORIZED USE OF THIS DRAWING. SPORT SYSTEMS CANADA INC. IS NOT RESPONSIBLE FOR LOCAL PERMITS AND OCCUPANCY REQUIREMENTS.



28 Industrial Drive, Box 940
Almonte, Ontario, Canada
K0A 1A0

www.ssci.ca
1.877.600.4667
T 613.256.1112
F 613.256.5876

CLIENT
SPORT SYSTEMS

TITLE
BL-PLAYER'S BENCH - 18'

REV.	DATE	DWG No.
	2021-11-08	BL-PB-18

SCALE	DES.	PAGE
N.T.S.	BAT	2 OF 2

BL-BP-18 - SHOWN